

# BAS-364-366

# BAS-370-375

Programmable Electronic Pattern Sewer



## Specifications

	BAS-364	BAS-366	BAS-370	BAS-375
Machine head	Lock stitch double rotary hook long arm machine			
Application	Light, heavy materials			
Sewing area X-Y	420 × 400 mm	650 × 400 mm	800 × 400 mm	1,200 × 400 mm
Feed mechanism	AC servo motor 400 W (X-Y feeding)			
Height of work clamp	50 mm (Stepping Presser Foot : 16 mm)			
No. of stitches	20,000 / 1pattern (Max. 10 patterns)			
Needle	1 (DP × 17 Max. #25)			
Rotary hook	Double			
Test function	Operation test function provided for use with low speed drive			
Safety device	Automatic stop function for activation in the event of misoperation realized with intermediate stop function and safety circuits.			
Machine motor	AC servo motor (330 W)			
Air pressure	0.5 Mpa			
Power supply	Three Phase 220 V, 380 V, 415 V (1,000 VA)			
Machine dimensions (mm) (W × D × H)	1,100 × 1,625 × 1,868	1,557 × 1,625 × 1,868	1,820 × 1,625 × 1,868	2,620 × 1,625 × 1,868
Weight	390 kg	400 kg	600 kg	620 kg

**BAS-364**

**BAS-366**

**BAS-370**

**BAS-375**

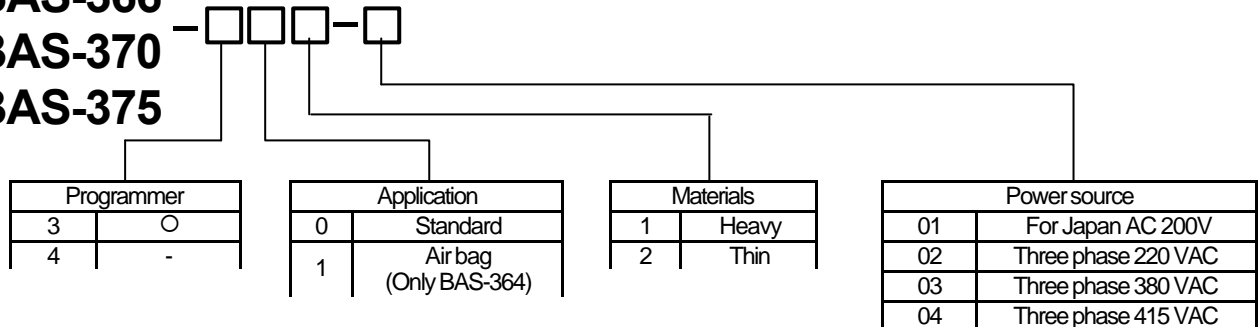

\*A different work clamp is used when sewing air bags, Furthermore, an stepping presser foot controller, beam sensor-type thread breakage detector and two-stage thread tensioner are included as standard equipment.

Option parts

[BAS-364, 366, 370, 375]

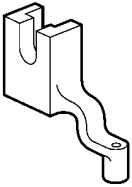
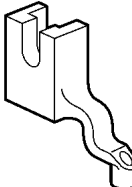
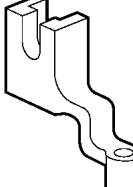
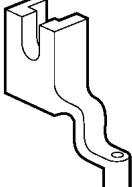
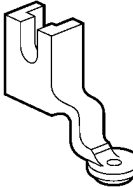
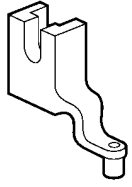
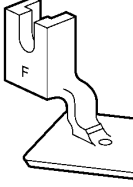
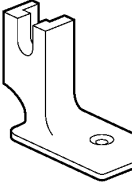
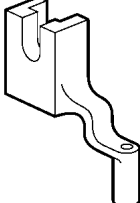
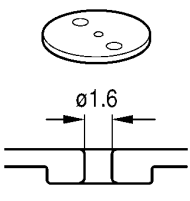
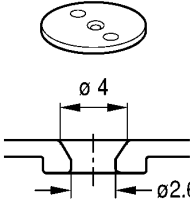
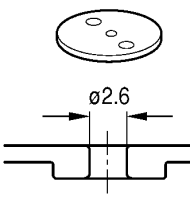
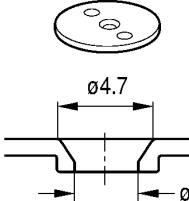
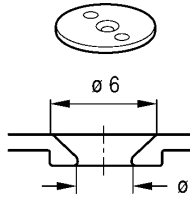
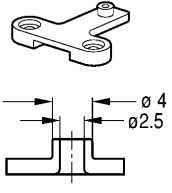
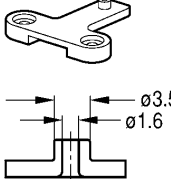
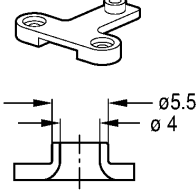
Presser foot, A 152283-101 (φ2.5)	S40214-001 (φ2.5)	Presser foot, B 152636-001 (φ4)	Presser foot, C 152637-001 (φ2)	Presser foot, D 154069-001 (φ8)
				
Presser foot, E 154089-001 (φ1.6)	Presser foot, F 157237-001 (φ2)	Presser foot, G 158592-001 (φ2)	Presser foot, J S13815-001 (φ2.5)	
				
Needle hole plate, A 156149-001 (φ1.6)	Needle hole plate, E 156153-001 (φ2.6)	Needle hole plate, F 156154-001 (φ2.2)	Needle hole plate, L S25110-001 (φ3.3)	Needle hole plate, 3 S40215-001
				
Bottom plunger, A 157795-101 (φ2.5)	Bottom plunger, B 157796-101 (φ1.6)	Bottom plunger, C S05137-101(φ4)		
				

Option parts

[BAS-364, 366]

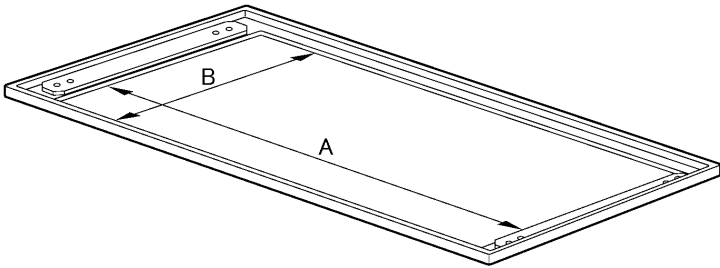
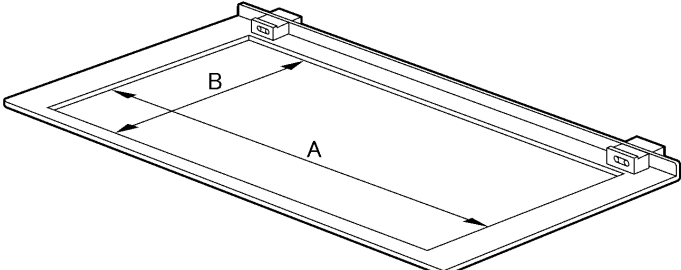
	Work clamp assy, S A=500 B=410 S37380-001
	Work clamp assy, L A=730 B=410 S37836-001
	Cassette plate assy, S A=440 B=410 S37378-001
	Cassette plate assy, L A=670 B=410 S37837-001

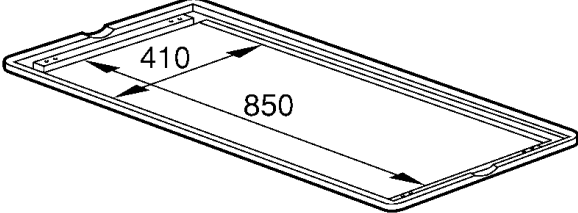
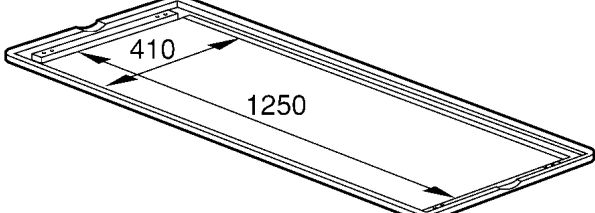
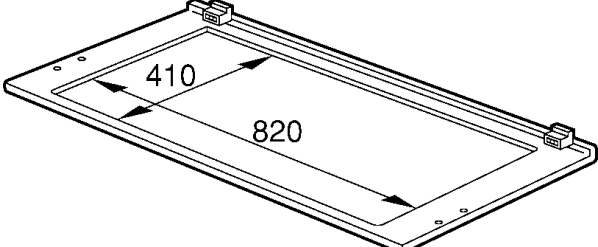
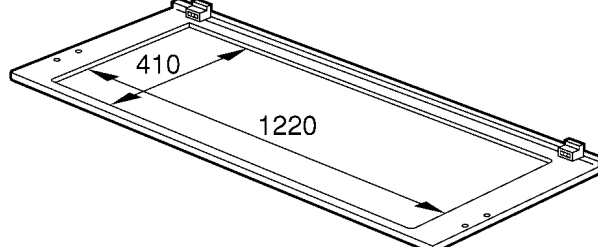
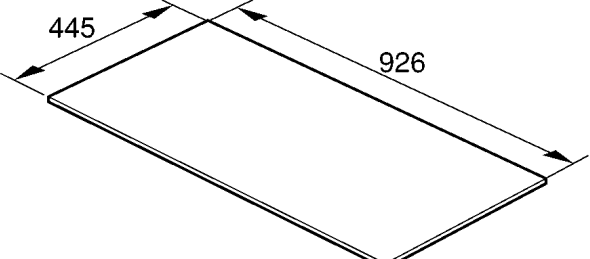
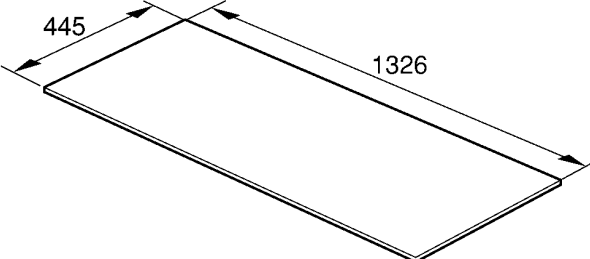
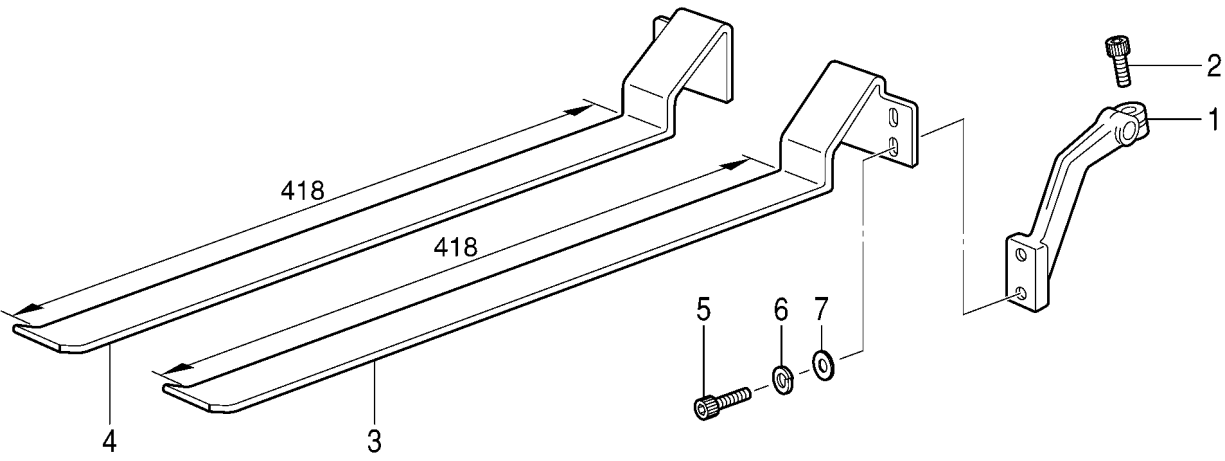
<p>Work clamp assy, S S16868-001</p>	<p>Work clamp assy, L S16869-001</p>
	
<p>Cassette plate assy, S S16789-001</p>	<p>Cassette plate assy, L S16746-001</p>
	
<p>Clamp plate lower, S1 / S16818-000 [T=1] Clamp plate upper, S1 / S16819-000 [T=1] Clamp plate lower, S2 / S29693-000 [T=2] Clamp plate upper, S2 / S29694-000 [T=2]</p>	<p>Clamp plate lower, L1 / S16750-000 [T=1] Clamp plate upper, L1 / S16751-000 [T=1] Clamp plate lower, L2 / S29691-000 [T=2] Clamp plate upper, L2 / S29692-000 [T=2]</p>
	
<p>1. Cloth clamp lever / S16763-009 2. Bolt 5 × 14 / 018501-436 3. Sub-presser (R) / S16934-001 4. Sub-presser (L) / S16933-001</p>	<p>5. Bolt 5 × 12 / 018501-236 6. Spring washer 2-5 / 028050-246 7. Plain washer 5 / 025050-236</p>
	

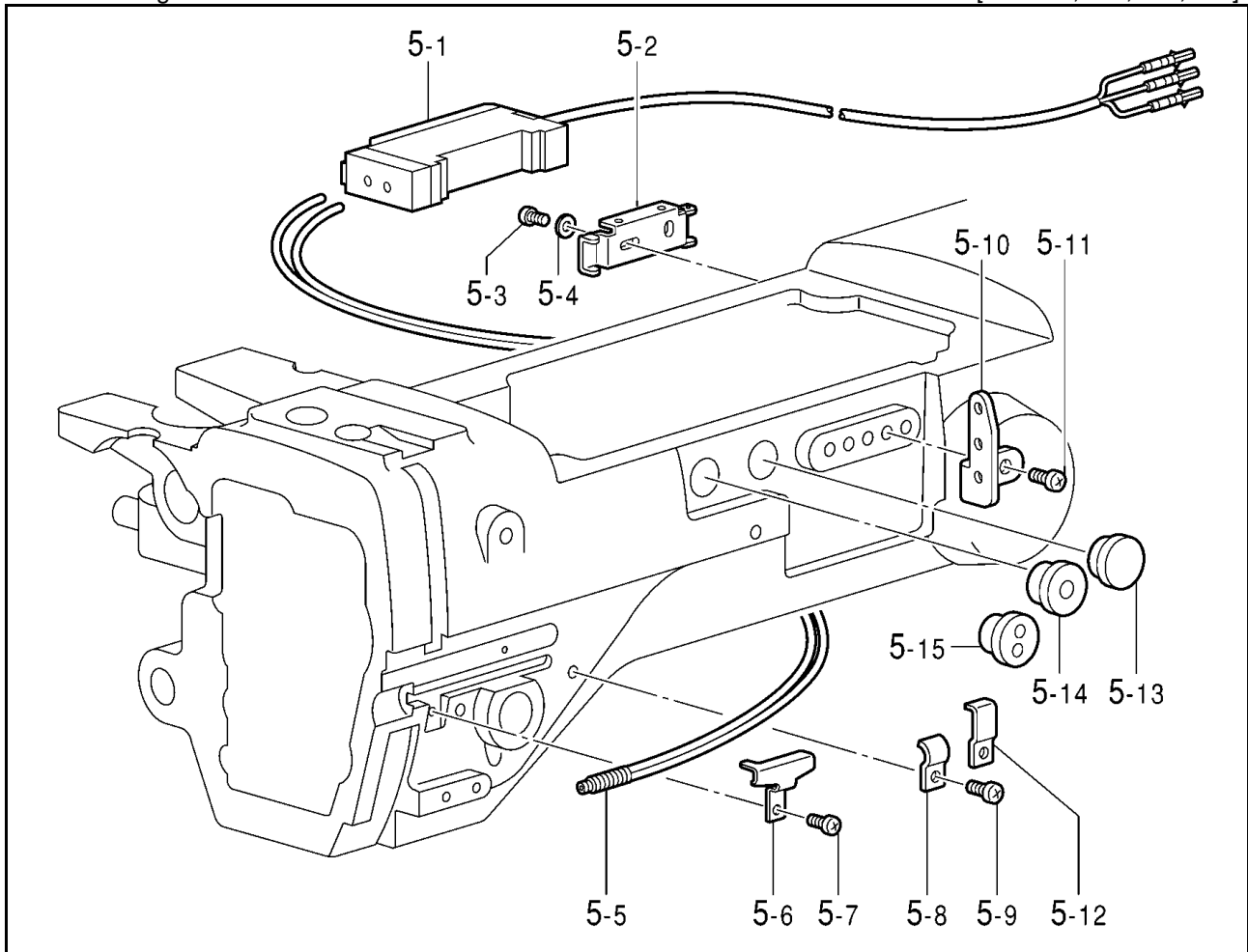

Ref. No.	Part name	Part code	Q'ty
5	Thread breakage detector (B) assy	S25115-001	1
5-1	Amp unit	S17031-000	1
5-2	Amp unit set plate (N)	S29469-000	1
5-3	Screw, pan M3×6	062300-612	2
5-4	Washer, plain M3	025030-232	2
5-5	Fiber unit (N)	S29468-100	1
5-6	Fiber unit presser plate	S25102-201	1
5-7	Screw, pan M3.57 – 40 × 6	062670-612	1
5-8	Cord holder	145595-001	2
5-9	Screw, pan M3.57 – 40 × 6	062670-612	2
5-10	Thread retainer	152889-001	1
5-11	Screw, pan M3.57 – 40 × 6	062670-612	2
5-12	Cord holder (L)	142268-001	2
5-13	Rubber cap, 18.5	S23337-009	1
5-14	Cord bush	157984-009	1
5-15	Cord bush	146020-009	1

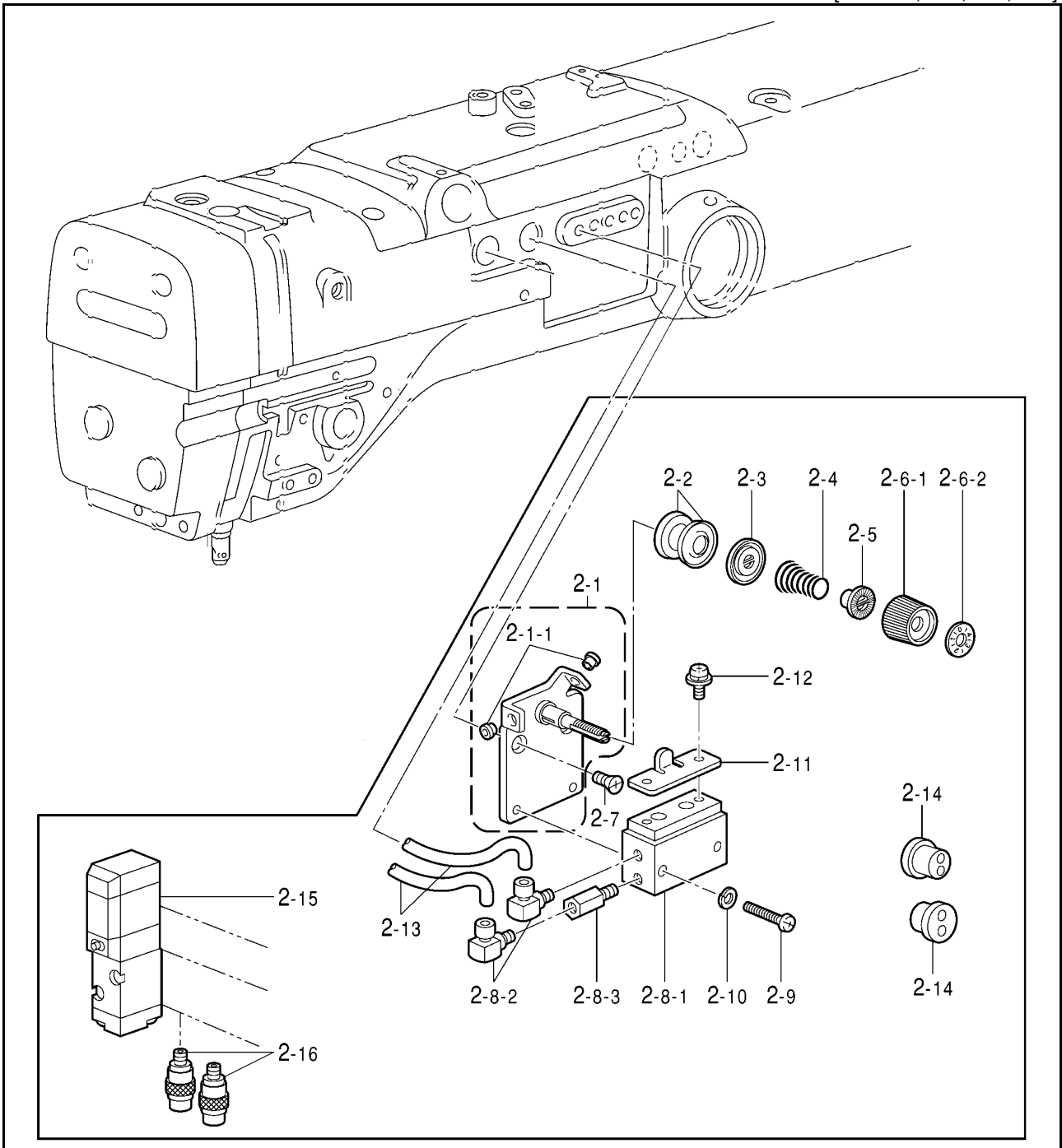

## Thread tension (For 2-step thread tension)

[BAS-364, 366, 370, 375]

Ref. No.	Part name	Part code	Q'ty
2	2-step thread tension assy	S29416-001	1
2-1	Thread tension assy	S24927-101	1
2-1-1	Thread bush	146924-000	2
2-2	Disc, tension	145446-001	2
2-3	Disc presser, tension	159805-001	1
2-4	Tension spring	148851-001	1
2-5	Flange washer, tension spring	144105-000	1
2-6	Tension nut assy	S11182-009	1
2-6-1	Control dial	S11183-009	1
2-6-2	Tension adjust scale plate	S11184-009	1
2-7	Screw, flat M4×8	004400-814	2
2-8	Twin rod cylinder assy	S30004-000	1
2-8-1	Twin rod cylinder	S12103-000	1
2-8-2	Tube elbow, M - 5HL - 4	S12150-000	2
2-8-3	Extended joint M - 5J	S24930-000	1
2-9	Screw, pan M4×20	062402-016	2
2-10	Washer, spring 2-4	028040-243	2
2-11	Countersink claw	S24931-001	1
2-12	Screw, pan (S/P washer) M4×8	052400-806	2
2-13	Air tube, L = 3250	S11440-002	2
2-14	Cord bush	146020-009	2
2-15	Solenoid valve	S29696-000	1
2-16	Half union, Q4M5	S18415-101	2

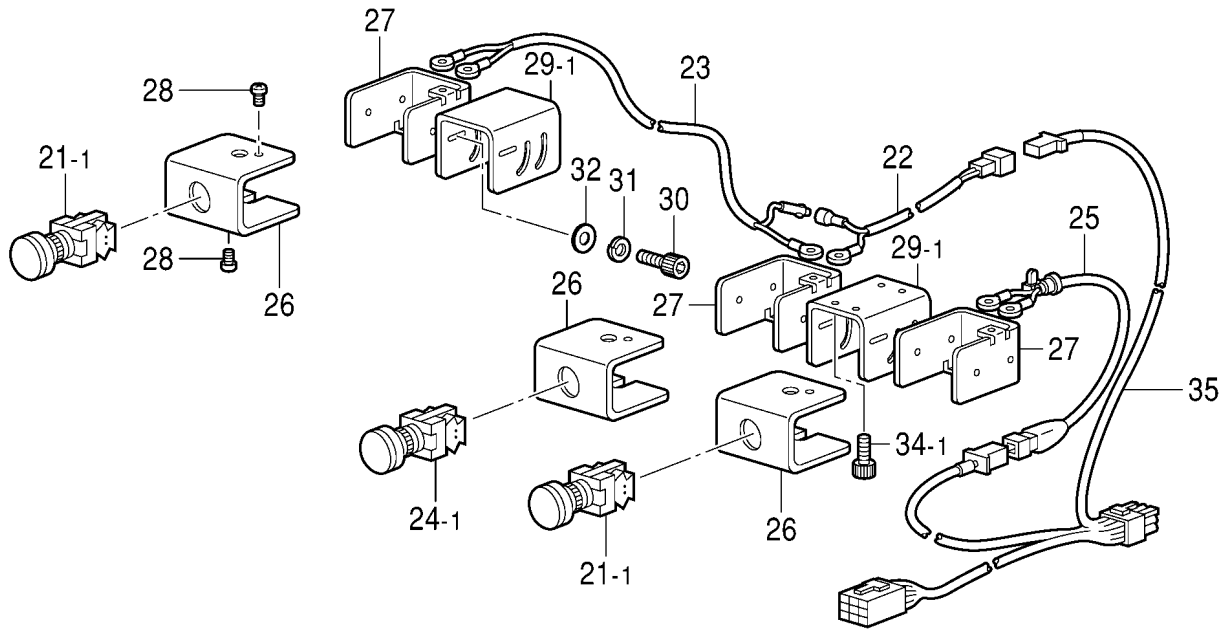

Ref. No.	Part name	Part code	Q'ty
21-1	SW-ABS310N (Mushroom type, green)	S11750-002	2
22	Hand switch harness (A)	S17012-000	1
23	Hand switch harness (B)	S17013-000	1
24-1	SW-ABS310N (Mushroom type, yellow)	S11750-000	1
25	EM harness	S24185-000	1
26	EM switch holder	S24184-009	3
27	EM switch indication plate	S33524-009	3
28	Screw, truss M4 × 8	008400-804	6
29-1	Switch bracket	S33525-001	2
30	Bolt, socket M5 × 12	018501-236	6
31	Washer, spring 2 - 5	028050-246	6
32	Washer, plain M5	025050-236	6
34-1	Bolt, socket M4 × 8	018400-836	4
35	Foot switch harness (B)	S17015-000	1

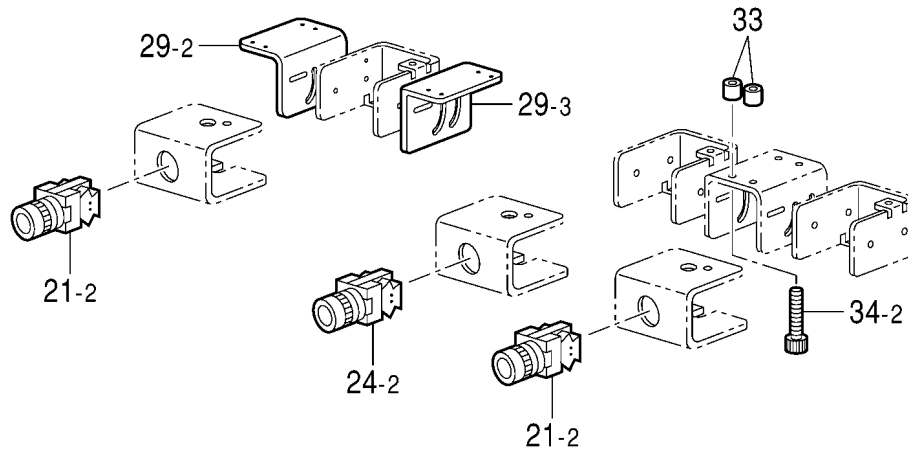

Ref. No.	Part name	Part code	Q'ty
21-2	SW-ABFS210N (with guard, green)	S17030-001	2
24-2	SW-ABFS210N (with guard, yellow)	S17030-002	1
29-2	Switch bracket right	S33526-001	1
29-3	Switch bracket left	S33527-001	1
33	Spacer	S31909-001	4
34-2	Bolt, socket M4 × 20	018402-036	4



< For air bags >

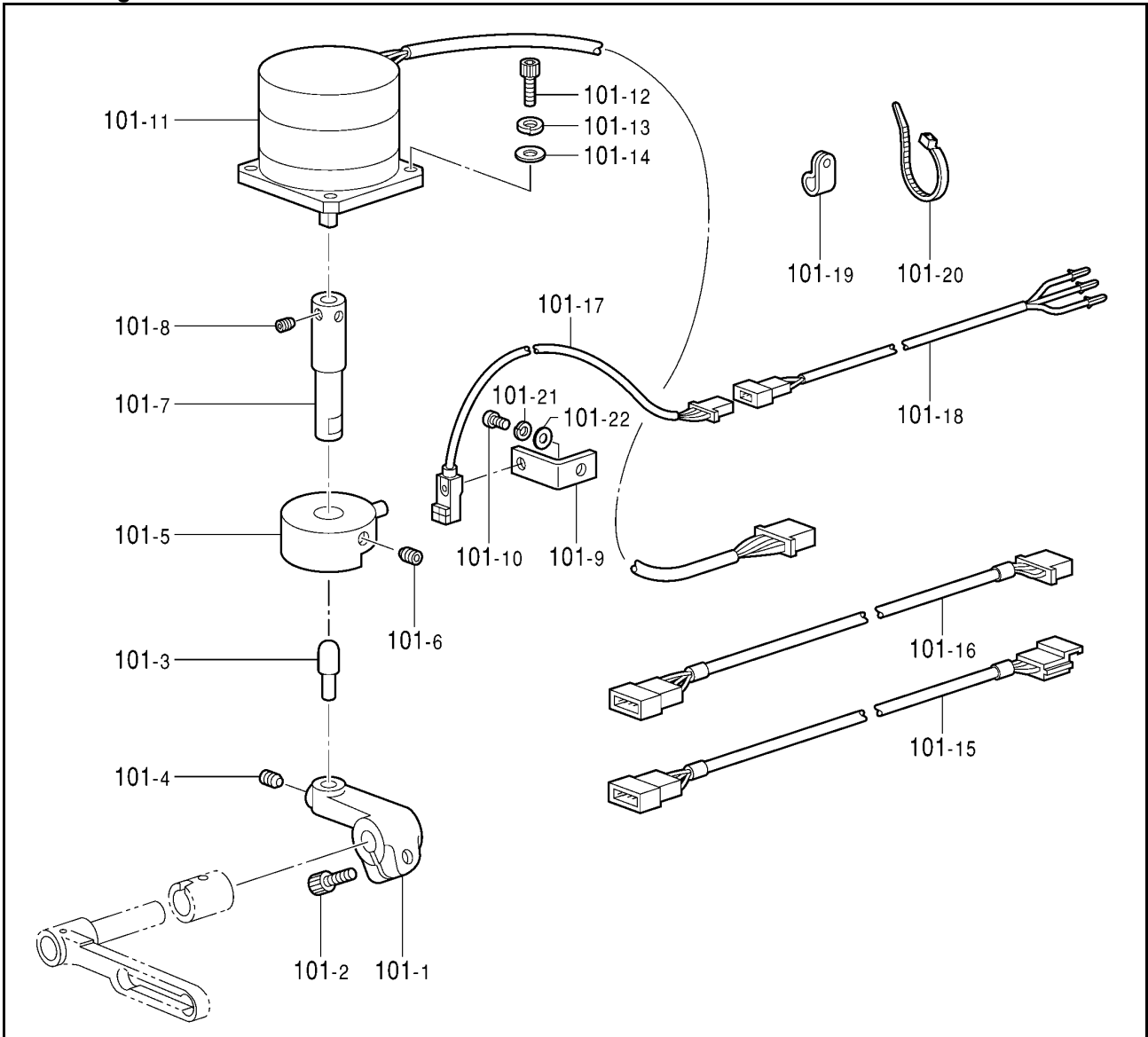

Ref. No.	Part name	Part code	Q'ty
101	Work clamp control assy	S29731-001	1
101-1	Stopper arm	S16989-001	1
101-2	Bolt, socket M6×16	018061-622	1
101-3	Stopper	S16940-001	1
101-4	Set screw, socket (CP) M4.76	014710-522	1
101-5	Work clamp control cam assy	S30025-001	1
101-6	Set screw, socket (FT) M5×5	012500-536	1
101-7	Control cam shaft	S16888-001	1
101-8	Set screw, socket (FT) M4×3.2	S23452-001	2
101-9	Hole sensor set plate	S16950-001	1
101-10	Screw, pan M3.57-40×8	062670-812	1
101-11	BH-200575042-B04	Z25701-001	1
101-12	Bolt, socket M4×12	018401-222	4
101-13	Washer, spring 2-4	028040-242	4
101-14	Washer, plain S 4	025040-132	4
101-15	Pulse motor harness (A)	S20098-000	1
101-16	Pulse motor harness (B)	S20099-000	1
101-17	Hole sensor	S20083-000	1
101-18	Head sensor harness (C)	S20068-000	1
101-19	Cord holder (5N)	S00480-000	1
101-20	Band PLTIM	S04557-000	2
101-21	Washer, spring 2-3.5	028350-242	1
101-22	Washer, plain S 4	025040-132	1

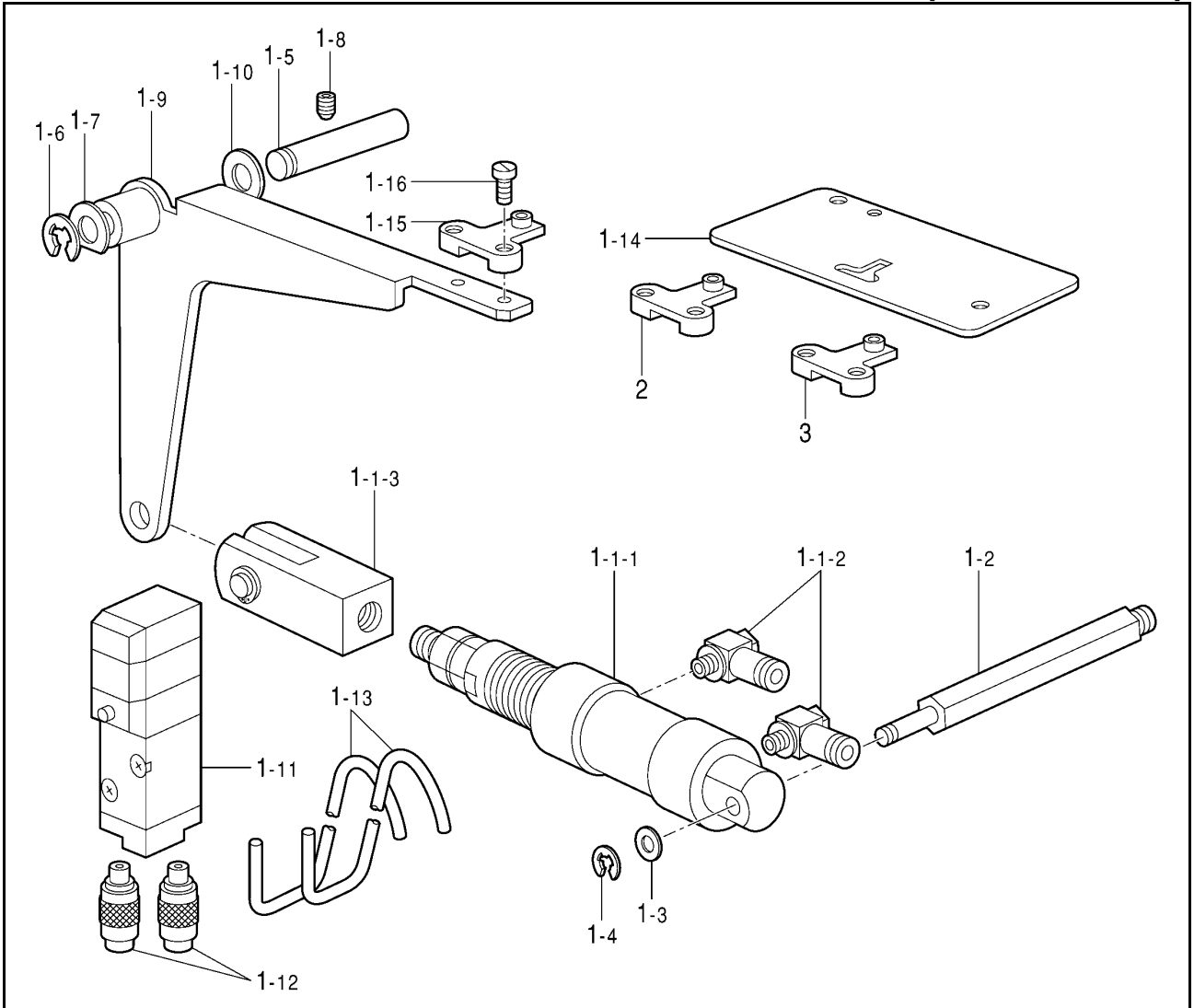

Ref. No.	Partname	Part code	Q'ty
1	Bottom assy	S37397-001	1
1-1	Bottom cylinder assy	S16893-000	1
1-1-1	Cylinder	S16903-000	1
1-1-2	Elbow M5	S03820-000	2
1-1-3	Y-type fitting	S16936-000	1
1-2	Cylinder support shaft	S16902-001	1
1-3	Washer, plain M6	025060-232	1
1-4	Retaining ring, E4	048040-342	1
1-5	Belt shift bar	141574-001	1
1-6	Retaining ring, E7	048070-342	1
1-7	Washer	110367-001	1
1-8	Set screw, socket (FT) M6×6	012060-636	1
1-9	Bottom lever	S16905-101	1
1-10	Washer	153596-001	1
1-11	Air valve	S29696-000	1
1-12	Half union (Q4M5)	S18415-001	2
1-13	Air tube 4-G (L=1310)	S08168-000	2
1-14	Bottom needle plate	S16725-000	1
1-15	Bottom plunger (A)	157795-101	1
1-16	Screw, M3.18	100080-003	2
2	Bottom plunger (B)	157796-101	1
3	Bottom plunger (C)	S05137-101	1